

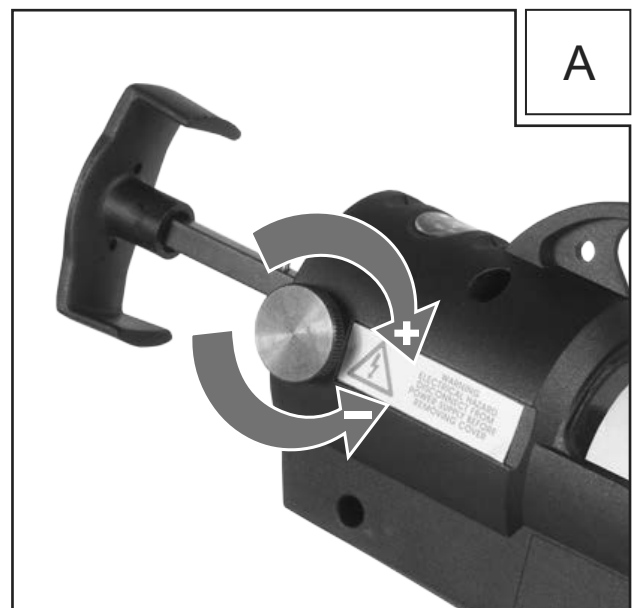

3150-43 • P-543-ECO

Operating Instructions Hotmelt Applicator

Please read carefully before
attempting operation



SAFETY INSTRUCTIONS

Do not touch the nozzle or molten adhesive with bare skin as they are hot - the operating temperature of this tool is approximately 200°C / 392°F (LT 120°C / 248°F). Protective gloves should always be worn. Careless handling can cause skin burns. If molten adhesive comes into contact with the skin, immerse the affected area immediately in plenty of cold water. Seek medical advice if necessary. In addition to the safety instructions herein, any statutory regulations, local fire insurance regulations, or other generally valid "regulations for accident prevention" must be complied with when using this tool.

Repairs should only be undertaken by competent personnel with the adequate electrical knowledge. Before proceeding with any maintenance or repair operation, disconnect the tool from the mains electricity supply. If in doubt, contact your supplier.

- WARNING - This tool must be placed on its stand when not in use; do not leave the tool unattended when switched ON.
- Place the tool on its stand after use and allow it to cool down before storage.
- Never use the tool if it is damaged in any way. If the supply cord is damaged, it must be replaced by the manufacturer, its service agent or similar qualified persons in order to avoid a hazard.
- Do not use this tool whilst under the influence of drugs or alcohol.
- Do not use this tool in damp rooms, and do not expose to rain or moisture.
- Do not use this tool in the vicinity of any heat-sensitive materials, or any flammable materials, liquids, or gases, and do not apply to the same place for a long time.
- Only use extension cables with a wire cross-section of 1.5mm² / 16 a.w.g. and no more than 20m / 65 ft in length.
- Never pull on the tool's connecting cable.
- This tool is not intended for the use by persons (including children) with reduced physical, sensory or mental capabilities, or lack of experience and knowledge, unless they have been given supervision or instruction concerning use of the tool by a person responsible for their safety.

Do not connect to the main supply at this point!

1. Attach the tool stand [1]
2. Pull the plunger handle fully back [2]
3. Insert adhesive into the breach [3]
4. Operate trigger to push adhesive forward [4]
5. Connect to mains supply
6. Red light illuminates [5]
7. Wait 5 minutes to warm
8. Operate trigger to push adhesive forward to the reload position
9. Pull the trigger back to reload more adhesive
10. Load more adhesive and continue
11. To switch off the tool, disconnect from the mains supply

FEED ADJUSTMENT [A]

Rotate the thumbwheel clockwise ("+" direction) to reduce the amount the plunger moves back when the trigger is released

Rotate the thumbwheel anti-clockwise ("- direction) if plunger cannot be pulled back to reload the tool

A balance should be found that allows the plunger to move forward yet still allows the gun to be reloaded

**Do not over tighten the thumbwheel
this will cause the feed bar to become stuck!**

AVOIDING PROBLEMS

- Ensure that tool has reached temperature before operating.
 - Do not leave tool switched on for long periods without use
 - If tool is not to be used for more than 40 minutes, switch off and restart when required.
 - Never lay the tool on its side. Always use stand provided, the optional bench stand or the suspension unit.
 - Only use adhesives designed for use with this tool.
-

GUARANTEE AND REPAIRS

This tool is guaranteed against faulty workmanship and materials for a period of 12 months from the date of purchase. Within this warranty period the manufacturers undertake, at their discretion, to either repair or replace any tool proved to be defective (proof of purchase will be required for verification). This guarantee is invalidated if the tool is opened, or modified in any way, or if adhesive formulations other than those supplied by the tool's manufacturer are used. Warranty claims attributable to improper, or careless, use or handling, and to normal wear, are excluded from this guarantee.

The supplier's and manufacturer's only obligation shall be to replace such tools that are proved to be defective. Neither supplier nor manufacturer shall be liable for any injury, loss or damage, direct or consequential, arising out of the use, or the inability to use, this tool. The user shall determine the suitability of this product for its intended use, and the user assumes all risks and liability whatsoever in connection therewith.

The manufacturer reserves the right to improve or modify this product without prior notice.

For help with fault finding, please visit our website:
For optional part, please visit our website:

www.poweradhesives.com

Power Adhesives Ltd.

Basildon, Essex, England
SS13 1TN

Telephone: +44 (0) 1268 885 800 Facsimile: +44 (0) 1268 885 810
sales@poweradhesives.com

