

**808B-12 • 808B-15**

## **Operating Instructions Hotmelt Applicator**

**Please read carefully before  
attempting operation**

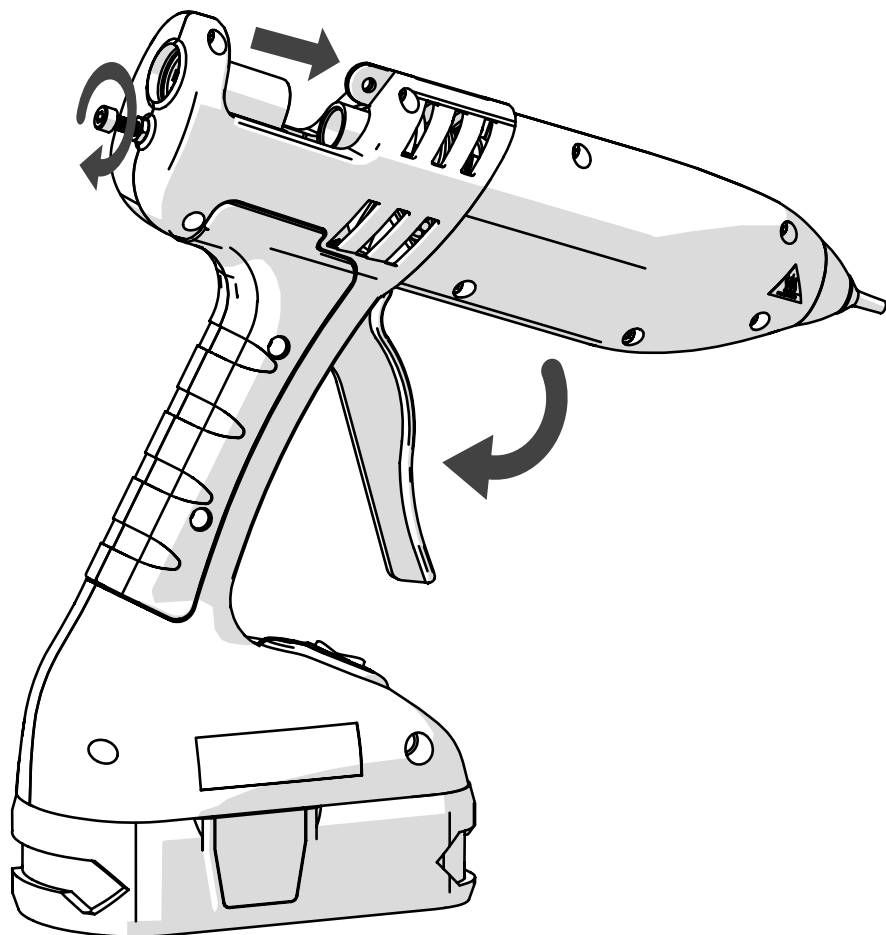
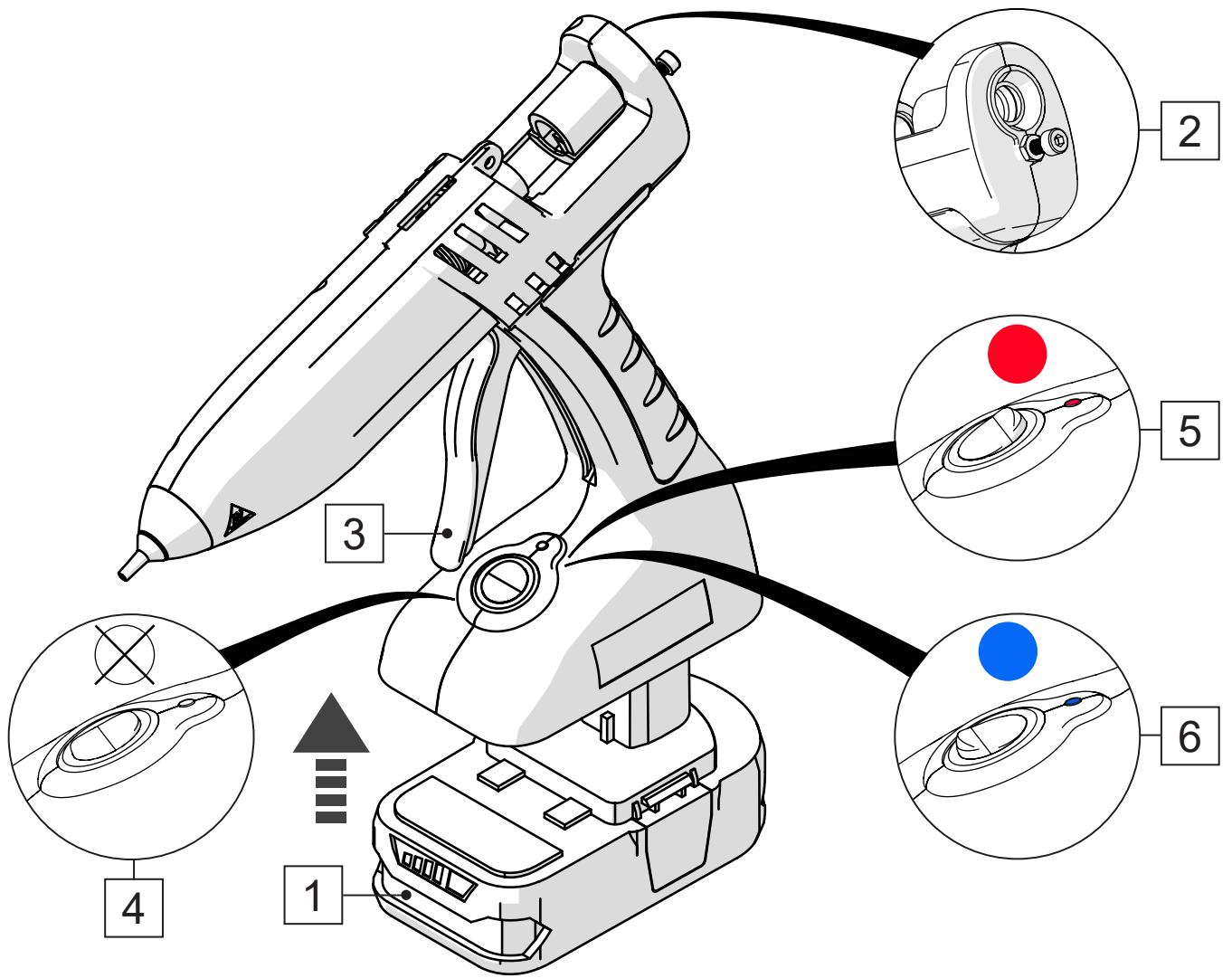

## SAFETY INSTRUCTIONS

**Do not touch the nozzle or molten adhesive with bare skin as they are hot - the operating temperature of this tool is approximately 200°C / 392°F HOTMELT temperature mode (Eco temperature mode 165°C / 329°F). Protective gloves should always be worn. Careless handling can cause skin burns.** If molten adhesive comes into contact with the skin, immerse the affected area immediately in plenty of cold water. Seek medical advice if necessary. In addition to the safety instructions herein, any statutory regulations, local fire insurance regulations, or other generally valid "regulations for accident prevention" must be complied with when using this tool.

Repairs should only be undertaken by competent personnel with adequate electrical knowledge. Before proceeding with any maintenance or repair operation, disconnect the battery from the tool. If in doubt, contact your supplier.

- WARNING - Do not leave the tool unattended when switched ON.
- Never use the tool if it or the battery is damaged in any way.
- Do not use this tool whilst under the influence of drugs or alcohol.
- Do not use this tool in damp rooms, and do not expose to rain or moisture.
- Do not use this tool in the vicinity of any heat-sensitive materials, or any flammable materials, liquids, or gases, and do not apply to the same place for a long time.
- Turn off the tool when attaching and disconnecting the battery pack.
- Do not place battery packs near a fire or other heat source, nor incinerate or dispose of batteries in a fire, as they could explode.
- When not connected to the tool, protect the battery's contacts from short-circuits, and place electrical tape over the contacts before disposal/recycling.
- This tool is not intended for use by persons (including children) with reduced physical, sensory or mental capabilities, or lack of experience and knowledge, unless they have been given supervision or instruction concerning use of the tool by a person responsible for their safety.

## USING THE TOOL

1. Ensure that the switch is off **4** before connecting the battery **1**
2. Load the tool by inserting an adhesive stick into the rear **2**
3. Operate the trigger to feed the stick forward until resistance is felt **3**
4. Switch on tool in HOTMELT **5** or ECO **6** mode and wait 3 minutes to warm
5. Operate the trigger to extrude adhesive until the stick has been completely drawn into the rear of the tool
6. Insert a new stick into the tool **2**
7. Switch off the tool when work is complete **4**

## AVOIDING PROBLEMS

- Ensure that tool has reached temperature before operating.
- Do not leave tool switched on for long periods without use. If tool is not to be used for more than 40 minutes, switch off and restart when required.
- Never lay the tool on its side. Always stand tool upright or the optional suspension unit.
- Only use adhesives designed for use with this tool.
- Never remove a partially used glue stick. This can lead to irreparable damage.
- Hotmelt glue can be used instead of nails, staples, tapes, and liquid glues. However they should not be used in place of structural connections when heavy loads are involved.
- Do not use hotmelt glue for objects that are exposed to extreme heat.

## GUARANTEE AND REPAIRS

This tool is guaranteed against faulty workmanship and materials for a period of 12 months from the date of purchase. Within this warranty period the manufacturers undertake, at their discretion, to either repair or replace any tool proved to be defective (proof of purchase will be required for verification). This guarantee is invalidated if the tool is opened, or modified in any way, or if adhesive formulations other than those supplied by the tool's manufacturer are used. Warranty claims attributable to improper, or careless, use or handling, and to normal wear, are excluded from this guarantee.

The supplier's and manufacturer's only obligation shall be to replace such tools that are proved to be defective. Neither supplier nor manufacturer shall be liable for any injury, loss or damage, direct or consequential, arising out of the use, or the inability to use, this tool. The user shall determine the suitability of this product for its intended use, and the user assumes all risks and liability whatsoever in connection therewith.

The manufacturer reserves the right to improve or modify this product without prior notice.

For help with fault finding or optional parts, please contact us via our website:

**[www.poweradhesives.com](http://www.poweradhesives.com)**



Do not dispose of electrical appliances as unsorted municipal waste, use separate collection facilities of the community. Ask your local council for information regarding collection. If electrical appliances are disposed of in an uncontrolled manner, dangerous substances may leak into groundwater and thus enter the food chain, or flora and fauna may be poisoned.

## **Power Adhesives Ltd.**

Basildon, Essex, England  
SS13 1TN

Telephone: +44 (0) 1268 885 800 Facsimile: +44 (0) 1268 885 810  
[sales@poweradhesives.com](mailto:sales@poweradhesives.com)

